

OPERATION & SERVICE MANUAL

DRUM-LRT-DC-I (POWERED LIFT & MAUAL ROTATION)



Vestil Manufacturing Corp.
2999 North Wayne St., Angola, IN 46703
Ph: 260-665-7586 . Fax: 260-665-1339
E-mail: Sales@vestil.com
Website: www.vestil.com

General

Read and follow the instructions contained in this operating manual without fail!

Only trained, well-informed personnel, who have been instructed in accordance with this operation manual, may use or work on the machine.

Liability or guarantee is waived if:

- The instructions in this operating manual are not observed.
- The high-lift stacking truck is operated, cleaned or maintained incorrectly.
- Alterations to the functions are carried out without the consent of manufacturer.
- Original spare parts are not used.

Safety instructions

This chapter informs the user about residual dangers relating to the correct use of the products. It contains generally valid safety instructions which must be observed.

Safety instructions relating to specific actions or situations are listed prior to the respective action and/or description of the situation in the chapter.

Principles

This product complies with state-of-the-art technical standards and recognized safety regulations, but there are still dangers which may occur which must be considered.

Only operate the product in a perfect condition and observing the information contained in the operating manual.

The operator is responsible for integrating the product with as little risk as possible into his working environment. This obligation continues through every phase of the products lifespan, beginning at the planning stage. Residual dangers are to be minimized.

Only trained, competent personnel who have been instructed using the operating manual and the product are permitted to work with the truck.

The operating manual must be understood (responsibility, checking)

Declaration:

I have read this manual and, in particular, have taken note of the caution.

Name	Date	Signature

Specification

SPECIFICATION

		DRUM-LRT-AIR
Capacity		550 lbs.
Lift Height		63"
Ground Clearance		2 ¾"
Lowered Height		0"
H. Overall Extended		81 7/8"
Head Dimension		34 13/16"
Loading Center		26 ¾"
Wheel Base		39 11/16"
Turning Radius		50 11/16"
Front Wheel		Ø7 x 2
back Wheel		Ø7 x 2
Overall Size		54 ½ x 36 x 86"
Lift Speed	Load	3.34"/s
	Unload	5.9"/s
Lower Speed	Load	4"/s
	Unload	2"/s
Net Weight		640 lbs.

Receiving Instructions

Every unit is thoroughly tested and inspected prior to shipment. However, it is possible that the unit may incur damage during transit. If you see damage when unloading, make a note of it on the SHIPPER RECEIVER.

Remove all packing & strapping material, inspect for damage. IF DAMAGE IS EVIDENT, FILE A CLAIM WITH THE CARRIER IMMEDIATELY! Also, check fork size, type of power unit, etc., to see that the unit is correct for the intended application.

Warnings & Safety Instructions

Insure that all employees understand and follow the following instructions

- Read and understand the owner's manual before using or servicing the stacker.
- Do not use the drum lifter if any damage or unusual noise is observed.
- Improper use of this drum lifter could result in injury and damage to load or equipment.
- Always watch the drum lifter and any load on it carefully when it is being used or moved.
- Do not overload this truck. Check capacity plate for loading weight and lifting height. Do not handle unstable loads.
- Operate truck only from designated operating load position.
- Make sure that the drum has been exactly clamped when to lift & rotate it.
- Avoid sudden stops or quick turns to prevent accidental tipping of the load.
- Park drum lifter on level surfaces and not in the way of other products
- When parked, lower the carriage completely and set parking brake by making sure handle is in vertical position.
- When parked, turn the key switch off.
- Travel slowly and with caution on slopes, always travel with load end down grades.
- Do not perform any modifications to the drum lifter without the manufacturer's approval. Failure to receive authorization for changes to the equipment could void the warranty.
- Do not use brake fluid or jack oil in the hydraulic system. If oil is needed, use an anti-wear hydraulic oil with a viscosity grade of 150 SUS at 100°F, (ISO 32 @ 40°C), or a non-synthetic transmission fluid.
- Use only replacement parts either supplied or approved by the manufacturer.

OPERATION

1. Before operation, turn the power ON, see if the battery meter shows fully charged or half charged.
2. Charge the battery before it is 1/4 used to prolong its work lift.
3. Push the lever to raise the clamp, pull the lever towards you to lower down the clamp. If the truck is heavily loaded, activate the lever slowly to avoid accidents.
4. Before lifting the load, follow these stages:
 - a. Drive close to the load
 - b. To attach a drum to the drum carriage, raise the locking mechanism at the top of the carriage until it is slightly above the height of the drum's top rim. Maneuver the unit up close to the drum. Open the jaw of the locking mechanism, then lower it until the lower part of the jaw is just at the bottom edge of the top rim of the drum. Push the unit up against the drum. If necessary, raise the carriage slightly so that the bottom of the jaw is even with the bottom of the top rim of the drum. Lock the jaw onto the top rim. Pump the push handle to raise the drum several inches off the floor. Lower the carriage foot by pushing down on the formed handle on the back side of the carriage. When the foot is below the bottom of the drum, rotate the so it protrudes under the drum, and release the handle. Use web belt to secure around the front of the drum, adjust and fasten it before tilting. The drum is ready to be rotated.
 - c. To rotate the drum, simply crank the hand wheel in the proper direction for the desired rotation of the drum. It is capable of rotating continuously through a 360 degree revolution.
 - d. To release the drum, rotate it to vertical position. Push down on the handle attached to the carriage foot and rotate the foot to the side, out from under the drum. Pull the push handle lever back until the drum lowers to the floor. Release the locking handle to disengage the drum and back the lift away.
 - e. The carriage's locking jaw can be adjusted for varying thicknesses of drum lips by turning the hex head bolt on top of the jaw either in or out for thinner or thicker lips, respectively.
5. Park the truck in a protected, leveled and solid place. Do not leave the truck parked with the key inside the key lock.

Cautions:

- Be sure the drum's top lip is securely locked in the carriage jaw and the bottom lip is retained by the carriage foot before tipping the drum.

MAINTENANCE

1. Only qualified and authorized personnel should be permitted to maintain, repair, adjust and inspect the stacker.
2. The work area should be clean, properly ventilated and the floor should be kept dry.
3. All parts of the lifting or rotate mechanism should be carefully and regularly inspected and maintained in a safe operating condition.

All hydraulic systems should be regularly inspected and maintained in conformance with the maintenance schedules. Lift cylinders, valves and other similar parts should be checked to assure that "drift" has not developed to the extent that it would create a hazard.

4. Please check the oil level every six months. Use anti-wear hydraulic oil with a viscosity grade of 150 SUS at 100°F (ISO 32 @ 40°C) or a non synthetic transmission fluid.
5. Use only replacement parts either supplied or approved by the manufacturer.

ORDERING REPLACEMENT PARTS

We take pride in using quality parts on the equipment. We are not responsible for equipment problems resulting from the use of unapproved replacement parts.

To order replacement or spare parts for this equipment, contact the factory.

In any communication with the factory, please be prepared to provide the machine's serial number, which is indicated on the machine plate.

Maintenance and repair

TROUBLESHOOTING GUIDE --

Warning: Before performing any task, always block drive wheel off of the ground.
Consult the factory for problems at time of installation, or for any problems not addressed below.

<u>Problem:</u>	<u>Possible cause(s):</u>	<u>Action:</u>
Unit will not raise; motor does not run	Loose wire Bad solenoid Upper limit switch out of adjustment Blown fuse Batteries discharged	Verify 24 volts at coil when raise is pushed, if no voltage; trace wiring back to tiller head looking for voltage on each side of the connectors until the bad connection is found. If voltage is present at the solenoid and the unit does not rise, remove the two wires to the coil and measure the coil resistance. It should be around 19 ohms. If it's open, or shorted replace the solenoid. Bypass upper limit switch and see if the unit raises...DO NOT TAKE IT ALL THE WAY UP... If it does rise, verify the limit switch is normally closed and will open when activated. If the limit switch is ok, try to adjust the switch accordingly so that the units raise height is approximately 7 to 8" Check fuses above motor controller Re-charge batteries
Unit will not raise; motor runs	Lower solenoid stuck on No hydraulic oil	Check to see if the lowering switch is stuck on. If it is, remove the tiller head via 3 screws on bottom and replace switch, or tap on switch to see if it can be freed up. Re-fill hydraulic oil
Unit will not lower	Loose wire; bad coil Upper limit switch out of adjustment	Verify 24 volts at coil when lower is pushed, if no voltage, trace wiring back to tiller head looking for voltage on each side of the connectors until the bad connection is found. If voltage is present at the coil and the unit does not lower, remove the connector to the coil and measure the coil resistance. It should be around 39 ohms. If it's open, or shorted replace the coil. Loosen hydraulic line at pump to relieve pressure build up. Re-adjust limit switch so unit stops at 7 to 8 inches above the ground.

		Look for binding in chain or rollers
Unit keeps blowing fuses when the raise button is pressed	Shorted solenoid for motor raise	Remove the wire to the solenoid coil on the pump motor. Measure the resistance; it should be around 19 ohms. If it is nearly zero ohms replace the solenoid.
Lifting height is not longer achieved	Hydraulic oil level is too low	Re-fill hydraulic oil when forks are lowered.
Unit jerks when lifting	Air in the system	Open vent screw on the lift cylinder with forks lowered all the way down. Lift forks with vent screw open until oil is free from air bubbles. Close the vent screw
Carriage raise, then drift down	Check valve or Solenoid valve leaking (contamination holding open the lowering valve or the check valve)	Remove & inspect. . Remove any load from the forks. . Remove the nut holding solenoid coil on the valve stem, and then unscrew the valve from the manifold. . Inspect the valve for contaminants, and the valve's o-rings and back-up washers for cuts, tears, and other damage. . With valve immersed in mineral spirits or kerosene, use a thin tool such as a small screwdriver or a small hex wrench to push the poppet in and out several times from the bottom end of the valve. The valve should move freely, about 1/16" from closed to open position. If it sticks in, the valve stem could be bent and will need to be replaced if it doesn't free up after cleaning. Blow the valve off with a compressed-air gun while again pushing the poppet in and out.
Oil leakage	Seals worn, cracked or damaged.	Replace with new one.
Battery doesn't charge up	a. Bad charger. b. Bad batteries. c. Loose battery connections	a. Check the output charger fuse. Verify fuse is good with an ohmmeter, or close visual (ohm meter best). Fuse is a 10Amp 250 Volt; GBD 10A. If it is good, check the battery's state of charge with a voltmeter. The charger must be connected to the battery in order to read the output voltage of the battery charger. Depending on the state of charge of the batteries, the voltage should be somewhere around 27 to 28 volts dc. b. If it is determined the batteries are dead, and need replaced, change the batteries. c. check all of the wiring connections to make sure they're both mechanically and electrically sound - specifically at the battery, and the motor.

DRUM - LRT - DC PARTS DRAWING

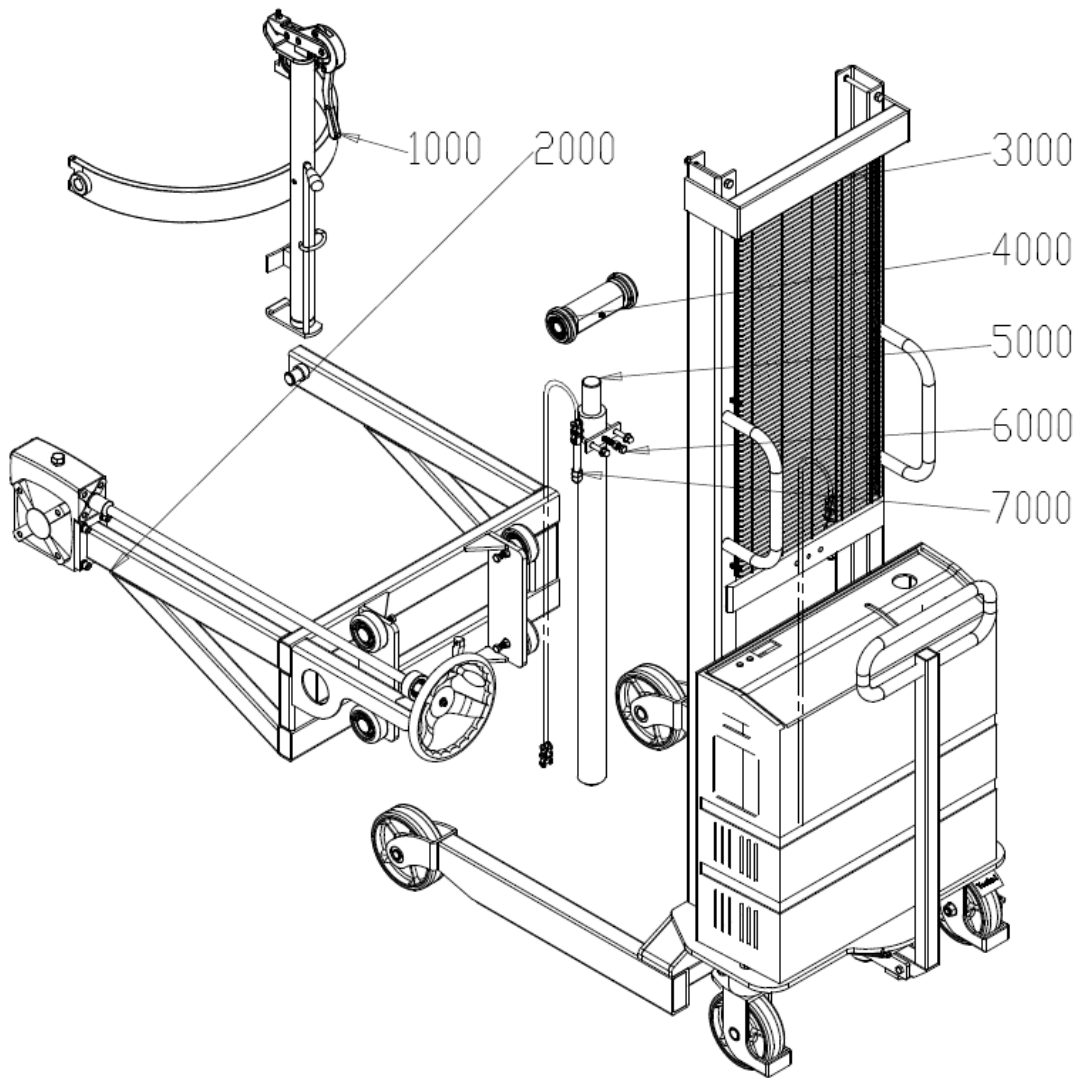

No.	Code No.	Descripton	Qty.
1000	VD-208B-010000	Clamp	1
2000	VD-208B-020000	Lift frame	1
3000	VD-208B-030000	Mast	1
4000	VD-208B-040000	Ø80 Chain wheel	1
5000	VD-208B-050000	Cylinder	1
6000	WS-150/25-010003	Cylinder bracket	1
7000	VD-208B-060000	Chain 12A	2

DRUM-LRT-DC FRAME

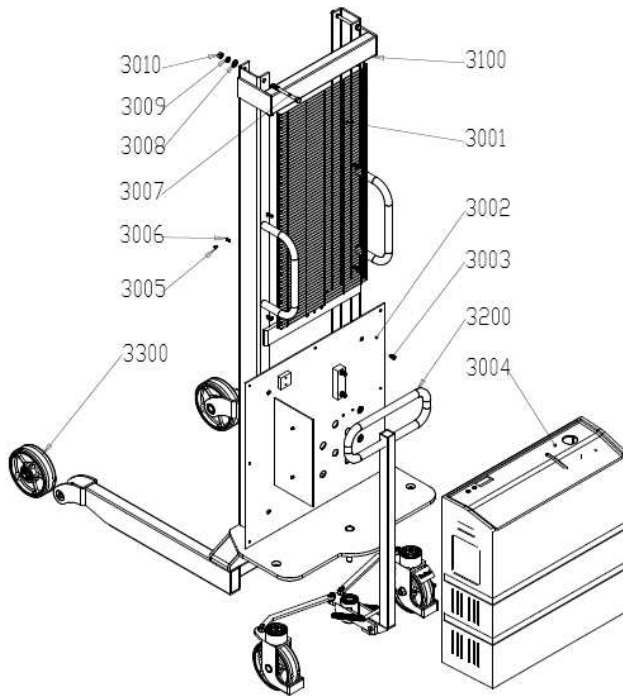

No.	Code No	Description	Qty.
3100	VD-208B-031000	Mast	1
3001	ES-100/25-010001	Mast safety wire mesh	1
3002	ES-100/25-014000	Panel plate	1
3003	GB/T70-85	Bolt M8x12	4
3004	ES-100/25-050001	Machine Cover	1
3005	GB/T818-85	Bolt M5x8	6
3006	ES-100/25-010002	Nut M5	6
3007	GB/T5782-86	Bolt M12x120	2
3008	GB/T97.1-85	Washer M12	2
3009	GB/T93-87	Lock washer M12	2
3010	GB/T6170-86	Nut M12	2
3200	ES-100/25-040000	Steering handle & steering system	1
3300	L180x50	Front wheel (Ø 7")	2

LIFTER ASSEMBLY

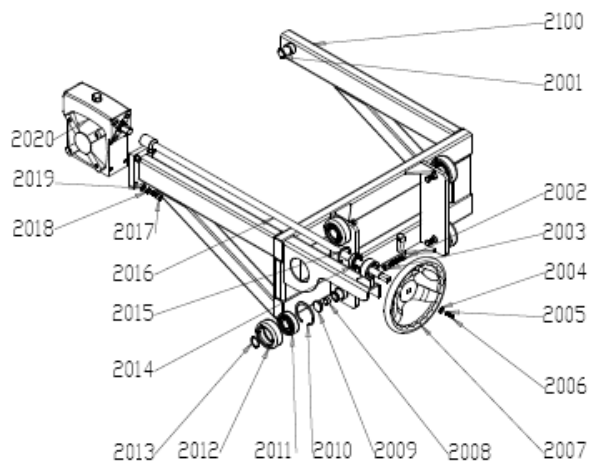

No.	Code No.	Description	Qty.
2100	VD-208B-021000	Lift frame	1
2001	GB/T894.1-86	Snap ring Ø25	1
2002	GB/T-5781-86	Bolt M10x55	4
2003	GB/T41-86	Nut M10	4
2004	GB/T96-85	Washer Ø6	1
2005	GB/T93-87	Lock washer Ø6	1
2006	GB/T70-85	Bolt M6x12	1
2007	VD-208B-021001	Hand Wheel	1
2008	JBW-200004	Collar	4
2009	JBW-200003	Adjusting pin	4
2010	GB/T893.1-86	Snap ring ø72	4
2011	GB/T276-94	Bearing Ø6306	4
2012	JBW-200002	Wheel ring	4
2013	GB/T894.1-86	Ring d30	4
2014	GB/T276-94	Bearing (6204ZZ)	1
2015	GB/T893.1-86	Snap ring ø47	1
2016	VD-208B-021002	Hand wheel shaft	1
2017	GB/T70-85	Bolt M10x25	4
2018	GB/T93-87	Lock washer Ø10	4
2019	GB/T95-85	Washer Ø10	4
2020	DM25/20-02301	Gear Box	1

CHAIN ASSEMBLY

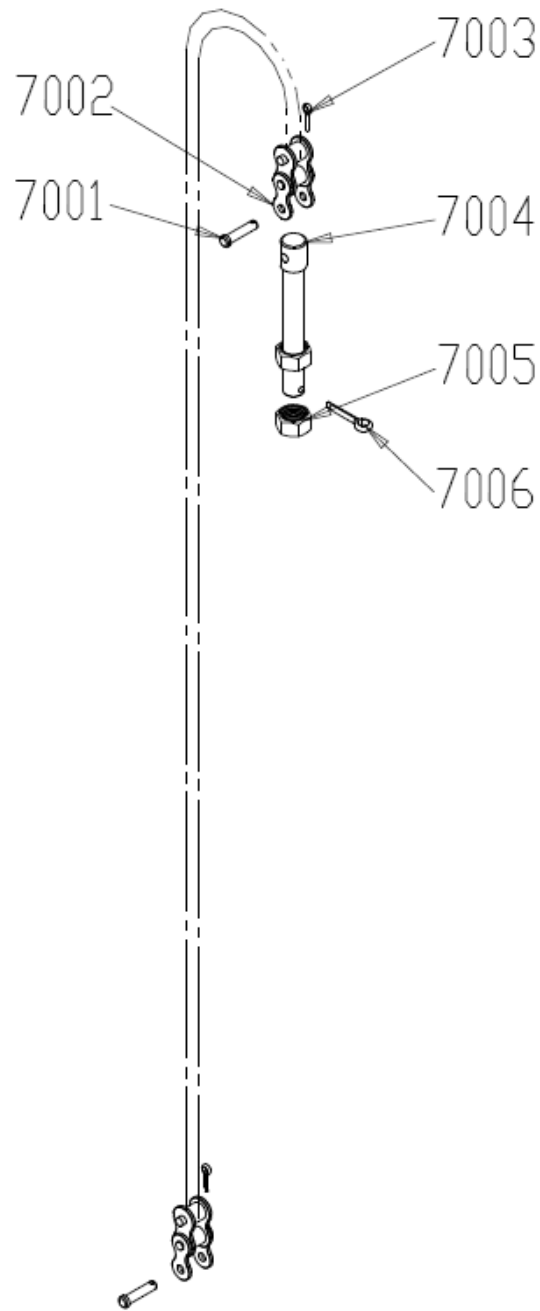

No.	Code	Description	Qty.
7001	LT(12A)-0001	Pin (12A)	2
7002	GB/T1243-94	Chain12A	4
7003	GB/T91-86	Pin Ø2.5x12	2
7005	GB/T6170-86	Nut M14	2
7004	VH-0003-03A	Adjusting bolt	1
7006	GB/T91-86	Pin Ø4x25	1

CHAIN WHEEL

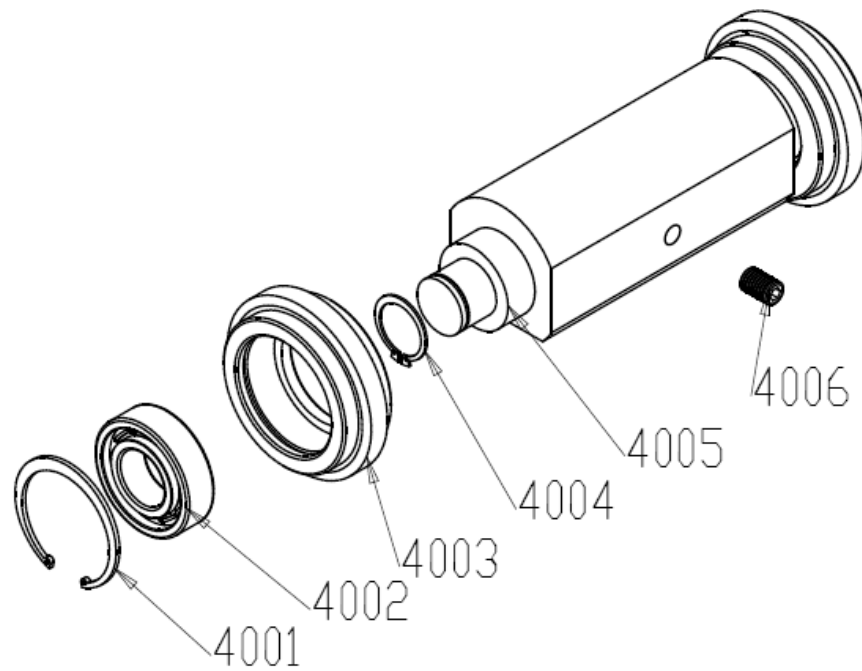

No.	Code No.	Description	Qty.
4006	GB/T77-85	Bolt M10x15	1
4005	D80-0002	Chain wheel seat	1
4004	GB/T894.1-86	Snap ring Ø25	2
4003	D80-0001	Chain wheel	2
4002	GB/T276-94	Bearing (6205)	2
4001	GB/T893.1-86	Snap ring Ø52	2

CYLINDER CLAMP

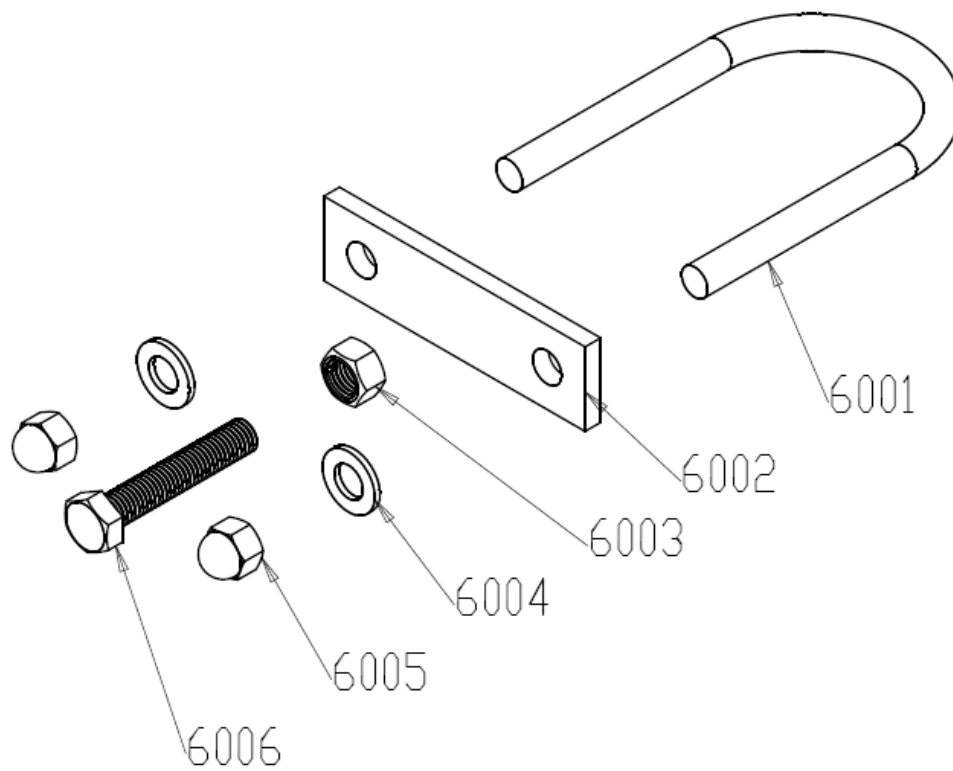

No.	Code No.	Description	Qty.
6006	GB/T-5781-86	Bolt M10x55	1
6005	GB/T923-88	Nut M10	2
6004	GB/T95-85	Washer Ø10	2
6003	GB/T41-86	Nut M10	1
6002		U bolt bracket	1
6001		U bolt Ø60	1

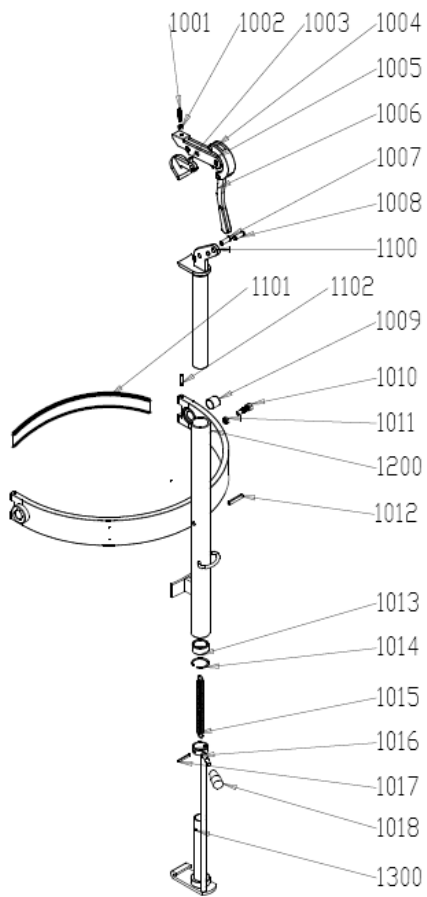

DRUM CLAMP

No.	Code No.	Name	Qty
1001	GB/T77-85	Allen screw M8x35	1
1002	GB/T6170-86	Nut M8	1
1003	VD-LRB-010001	Male clamp	1
1004	VD-LRB-010002	Bend arm	1
1005	VD-LRB-010003	Straight arm	1
1006	VD-LRB-010004	Handle	1
1007	GB/T894.1-86	Snap ring Ø10	10
1008	VD-LRB-010005	Pin	5
1009	JH2525	Bushing	1
1010	GB/T5781-86	Bolt M12x40	1
1011	GB/T6172-86	Nut M12	1
1012	GB/T879-86	Roll pin Ø10X50	1
1013	VD-LRB-010006	Collar	1
1014	GB/T893.1-86	C-clip Ø42	1
1015	VD-LRB-010007	Spring	1
1016	VD-LRB-010008	Collar	1
1017	GB/T879-86	Roll pin Ø6x40	1
1018	VD-LRB-010009	Handle	1
1100	VD-LRB-011000	Female clamp	1
1101		Strap	2
1102		Pin	1
1200	VD-LRB-012000	Craddle	1
1300	VD-LRB-013000	Base	1

STEERING SYSTEM

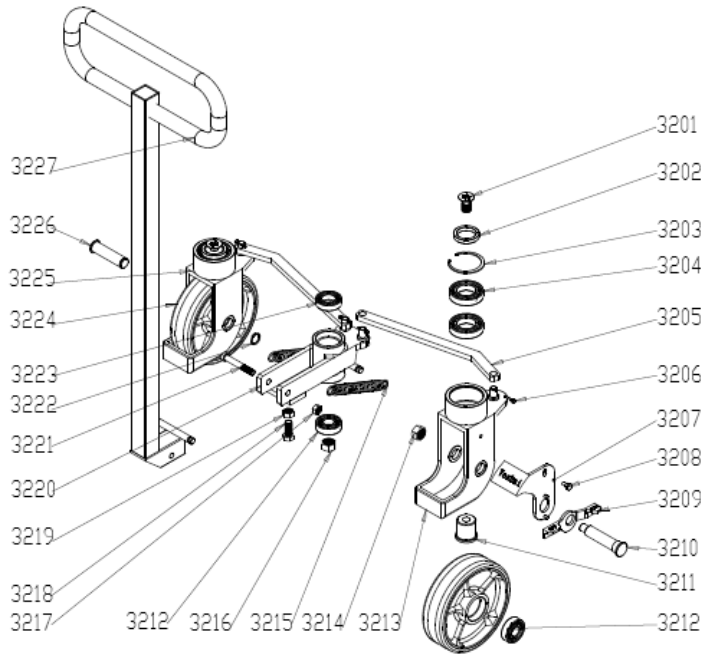

No.	Code No.	Description	Qty.
3201	GB/T2763-86	Bolt M16x30	2
3202	ES-100/25-040015	Washer	2
3203	GB/T893.1-86	Snap ring Ø62	2
3204	GB/T276-94	Bearing (6007ZZ)	4
3205	ES-100/25-040003	Steering column	2
3206	GB/T91-86	Pin Ø3.2x16	4
3207	ES-100/25-040008	Brake piece	1
3208	ES-100/25-040009	Brake holder pin	1
3209	ES-100/25-040010	Brake foot pedal	1
3210	ES-100/25-040007	Wheel shaft	1
3211	ES-100/25-040016	Pin	2
3212	GB/T276-94	Bearing (6204ZZ)	5
3213	ES-100/25-040012	Wheel Frame	1
3214	GB/T889-86	Nut M14	1
3215	ES-100/25-040005	Spring	2
3216	GB/T889-86	Nut M16	1
3217	GB/T889-86	Nut M10	1
3218	GB/T5781-86	Bolt M12x30	1
3219	GB/T6170-86	Nut M12	1
3220	ES-100/25-040006	Steering arm	1
3221	GB/T5780-86	Bolt M10x70	1
3222	GB/T894.1-86	Snap ring Ø20	1
3223	GB/T276-94	Bearing (6005ZZ)	1
3224	ES-100/25-040011	Wheel (180x50)	2
3225	ES-100/25-040013	Wheel frame	1
3226	ES-100/25-040002	Steering wheel shaft	1
3227	ES-100/25-041000	Steering Handle	1

FRONT WHEEL

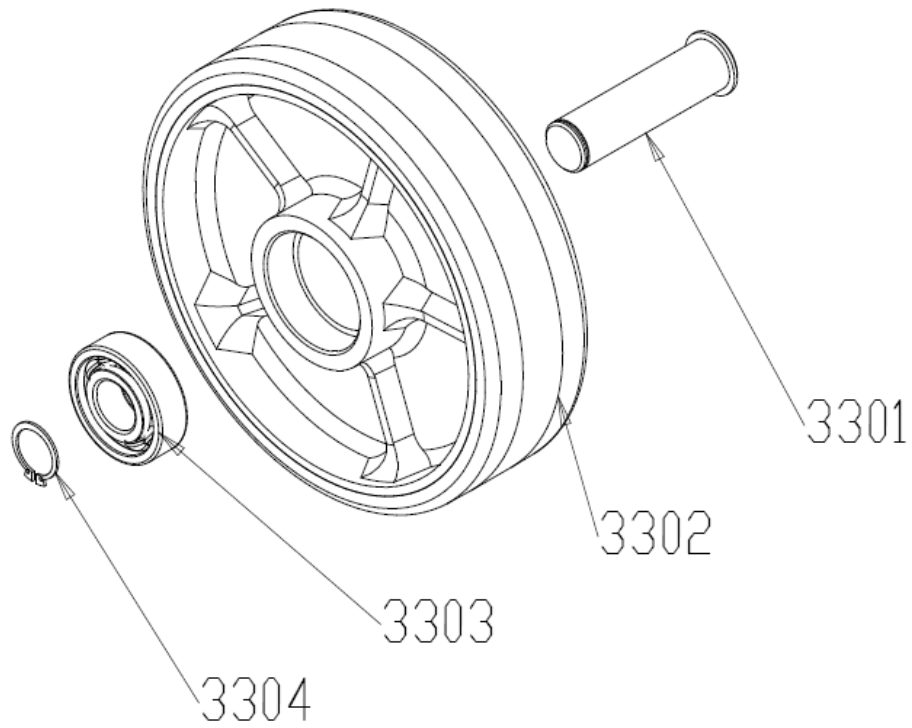

No.	Code	Name	Qty
3304	GB/T894.1-86	Snap ring Ø20	1
3303	GB/T276-94	Bearing (6204)	2
3302	ES-100/25-040011	Wheel (Ø7x2)	1
3301	MS-100/16-4003	Shaft	1

Air Power Pack



Vane air motor



Silencer

Hand Control

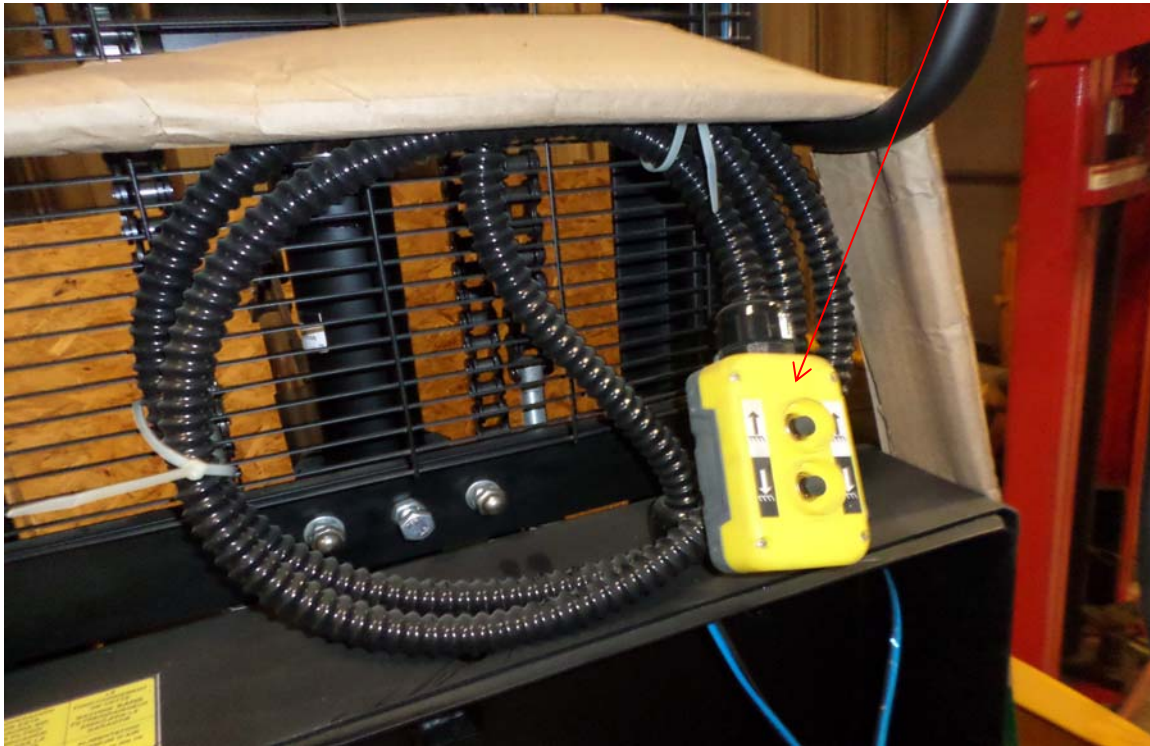

Quick connect Air hose male plug

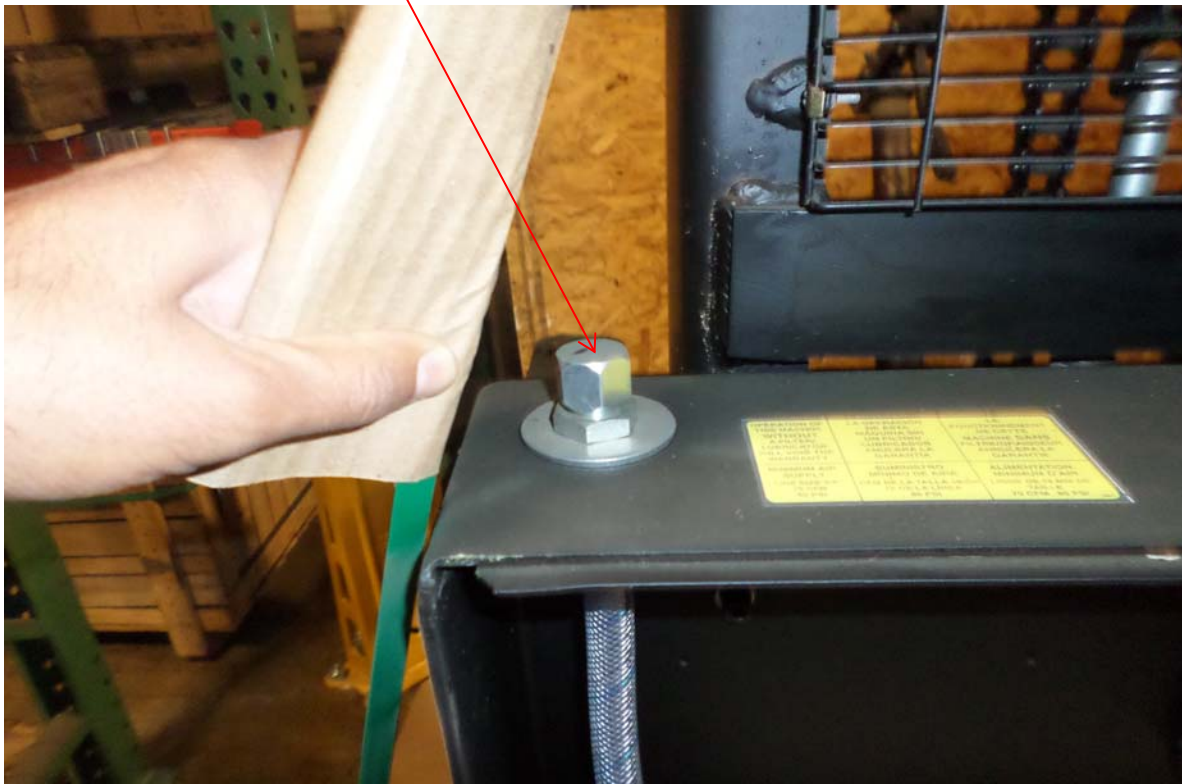



GLOBE AIRMOTORS B.V.

VA4CXXX10

GLOBE VANE AIR MOTORS

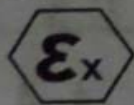

II Cat. 2 GDe T5



GLOBE

 **GLOBE Airmotors b.v.**
CE Model VA4C
Serie nr: 44120223
Made in The Netherlands
TEL: +31 172 426 608
www.globe-benelux.nl